

You now have the option to receive 1-1/4" frames without Gas Tank Mounts. Simply add the letters "NM" after the part number.

Ex: "K15006-NM"

Frame with this option will have this symbol



With Mounts

No Mounts

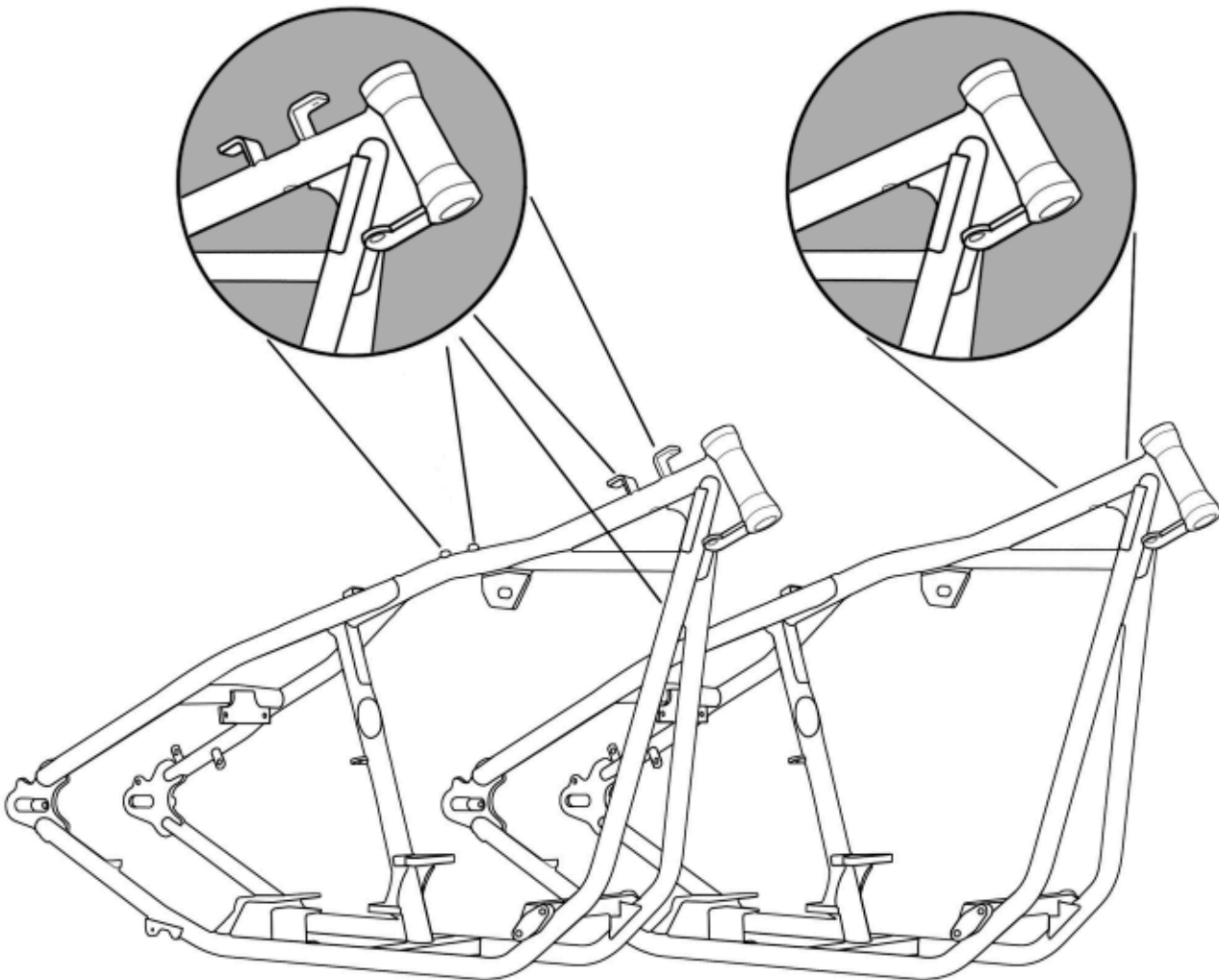

STANDARD

OPTIONAL

Swingarms

Fenders
Struts

Gas Tanks

Oil Tanks

Fwd
Controls

Kickstands

Handlebars

Exhaust

Misc.

SOFTAIL-STYLE FRAMES / 1-1/4" TUBING

- * Feature 1-1/4" thick wall, DOM steel tubing with 1-1/2" backbones
- * All frames are TIG-MIG welded & they will accept Panhead, Shovelhead and Evolution (except Twin Cam) engines with cylinders up to .200" taller than stock Evo
- * Frames designed for 5 or 6-speed Softtail-type transmissions
- * These frames have been an industry-standard since their introduction
- * Component Kits are included with purchase of frame. . .these kits are not sold separately

Swingarms

Fenders
Struts

Gas Tanks

Oil Tanks

Fwd
Controls

Kickstands

Handlebars

Exhaust

Misc.

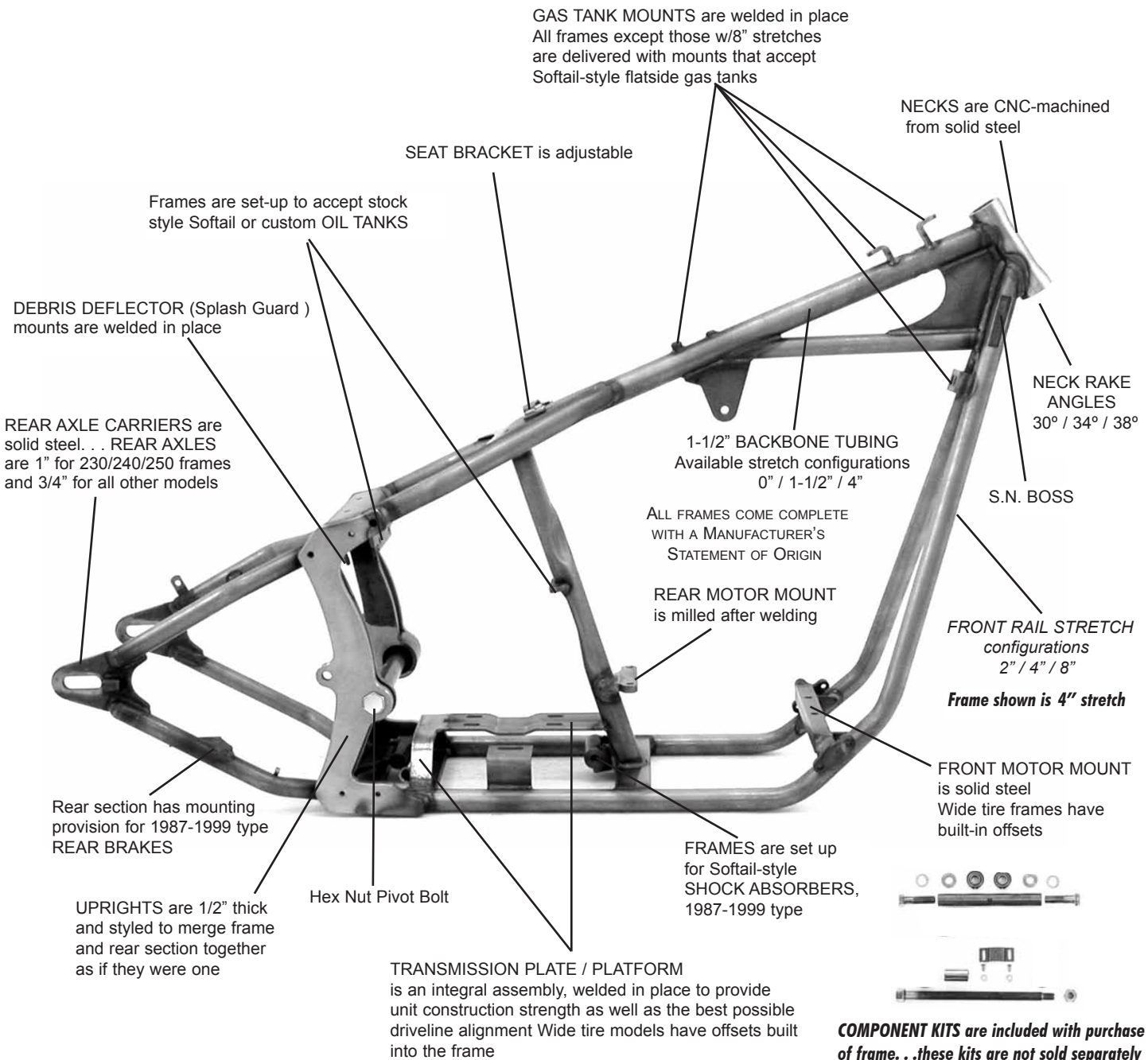

SOFTAIL-STYLE FRAMES / 1-1/4" TUBING / STOCK WIDTH

- * Designed for use with 1987-1999 rear sections (Rear section not included) see page 78
- * Frames equipped with stock style coil and oil tank mounts as well as gas tank mounts for flatside tanks
- * Available with neck rakes of 30° / 34° / 38°

Swingarms

Fenders
Struts

Gas Tanks

Oil Tanks

Fwd
Controls

Kickstands

Handlebars

Exhaust



SOLD SEPARATELY



	<u>PART #</u>	<u>STYLE</u>	<u>TIRE WIDTH</u>	<u>TUBING</u>	<u>RAKE</u>	<u>UP STRETCH</u>
	K15051	Softail	Stock	1-1/4"	30°	0"
	K15052	Softail	Stock	1-1/4"	34°	2"
Misc.	K15053	Softail	Stock	1-1/4"	38°	2"



SOFTAIL-STYLE FRAMES / 1-1/4" TUBING / 180 TIRE WIDTH

- * Designed for 180 width tire w/1-1/2" belt or 200 width tire with chain
- * Offset built into frame / No spacing required
- * Stock motor and transmission bolt-in
- * Component kit is included



KIT INCLUDED



SOLD SEPARATELY



SOLD SEPARATELY

PART #	STYLE	TIRE WIDTH	TUBING	RAKE	UP STRETCH	INCLUDES
K15060	Softail	180	1-1/4"	30°	0"	Rear Section Assembly
K15061	Softail	180	1-1/4"	34°	2"	Rear Section Assembly
K15062	Softail	180	1-1/4"	38°	2"	Rear Section Assembly

Frames

Swingarms

Fenders
Struts

Gas Tanks

Oil Tanks



KIT INCLUDED



SOLD SEPARATELY



SOLD SEPARATELY

PART #	STYLE	TIRE WIDTH	TUBING	RAKE	UP STRETCH	BACK BONE STR.	INCLUDES
K15067	Softail	180	1-1/4"	34°	4"	1-1/2"	Rear Section Assembly Kit
K15068	Softail	180	1-1/4"	38°	4"	1-1/2"	Rear Section Assembly Kit

Fwd
Controls

Kickstands

Handlebars

Exhaust

Misc.



SOFTAIL-STYLE FRAMES / 1-1/4" TUBING / 200 TIRE WIDTH

- * Designed for 200 width tire w/1-1/2" belt or chain
- * Offset built into frame. . .use 1/2" spacer between engine and inner primary cover
use 1/2" longer spacing on engine sprocket or pulley
- * Component kit is included

Swingarms



SOLD SEPARATELY

Fenders
Struts

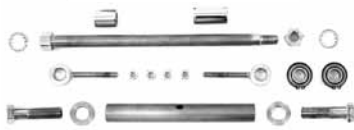

Kit INCLUDED



Oil Tanks



PART #	STYLE	TIRE WIDTH	TUBING	RAKE	UP STRETCH	BACK BONE STR.	INCLUDES
K15072	Softail	200	1-1/4"	34°	4"	1-1/2"	Rear Section Assembly Kit

Fwd
Controls

Kickstands



SOLD SEPARATELY

Handlebars



Kit INCLUDED

Exhaust



Misc.

PART #	STYLE	TIRE WIDTH	TUBING	RAKE	UP STRETCH	BACK BONE STR.	INCLUDES
K15079	Softail	200	1-1/4"	38°	8"	4"	Rear Section Assembly Kit



SOFTAIL-STYLE FRAMES / 1-1/4" TUBING / 230/240/250 TIRE WIDTH

- * Designed for 230/240 width tire w/1-1/2" belt or 250 width tire w/1-1/8" belt or chain
- * Offset built into frame...use 1" spacer between engine and inner primary use 1" spacing on engine sprocket or pulley
- * Component kit is included



IIII TT
SOLD SEPARATELY



KIT INCLUDED



Swingarms

Fenders
Struts

Gas Tanks

Oil Tanks

PART #	STYLE	TIRE WIDTH	TUBING	RAKE	UP STRETCH	INCLUDES
K15073	Softail	230/240/250	1-1/4"	34°	2"	Rear Section Assembly w/1" Axle Kit



TT IIII
SOLD SEPARATELY



KIT INCLUDED



Fwd
Controls

Kickstands

Handlebars

Exhaust

PART #	STYLE	TIRE WIDTH	TUBING	RAKE	UP STRETCH	INCLUDES
K15081	Softail	230/240/250	1-1/4"	38°	2"	Rear Section Assembly w/1" Axle Kit

Misc.



CURVED DUAL DOWN TUBE SOFTTAIL-STYLE 1-1/4" TUBE FRAMES w/HIDDEN AXLE

This line of curved dual down tube frames demonstrates KRAFT/TECH's commitment to quality & affordability without compromise.

Swingarms

- * Frames for 300/330 tires, 1-1/2" backbone, 1-1/4" thereafter, all DOM steel tubing, mandrel bent
- * Frames come with 38 degree or 40 degree neck rake angles, with front leg stretches of 0" or -2"
- * Engineered with a super-strong upper frame design with integral neck webbing that offers unparalleled strength with pleasing aesthetics
- * Dual down tubes curve smoothly and flow continuously to become the lower frame rails
- * These Softtail-style beauties are delivered complete with billet hidden axle rear section

Fenders
Struts

- * Rear axle carriers are available in 2 styles: Dagger and Curved Dagger. Axle cover set included.
- * Component kit consists of our best quality pivot axle w/flush mount stainless pivot bolts and bearings
- * Integral one-piece trans mounting plate is part of the frame structure, assuring unit construction strength and the best possible alignment
- * Will accept our great-looking oil tanks, our one-piece round top fenders and gas tanks
- * Axles are 1" in diameter

Gas Tanks

Oil Tanks

STRUTS SOLD SEPARATELY



Fwd
Controls

Kickstands

2 swingarm styles to choose from

Handlebars



Exhaust

DAGGER

CURVED DAGGER

Misc.



CURVED DUAL DOWN TUBE SOFTTAIL-STYLE FRAMES

Frames

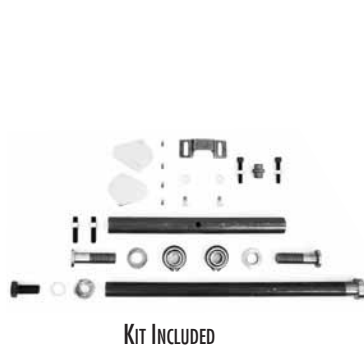

Swingarms

Fenders
Struts

DAGGER

PART #	STYLE	TIRE WIDTH	TUBING	RAKE	UP STRETCH	BACK BONE STR.	BACK BONE
K16125	Softail	300-330	1-1/4"	38°	0"	5"	1-1/2"
K16126	Softail	300-330	1-1/4"	40°	0"	5"	1-1/2"
K16127	Softail	300-330	1-1/4"	38°	-2"	5"	1-1/2"
K16128	Softail	300-330	1-1/4"	40°	-2"	5"	1-1/2"

Gas Tanks

Oil Tanks

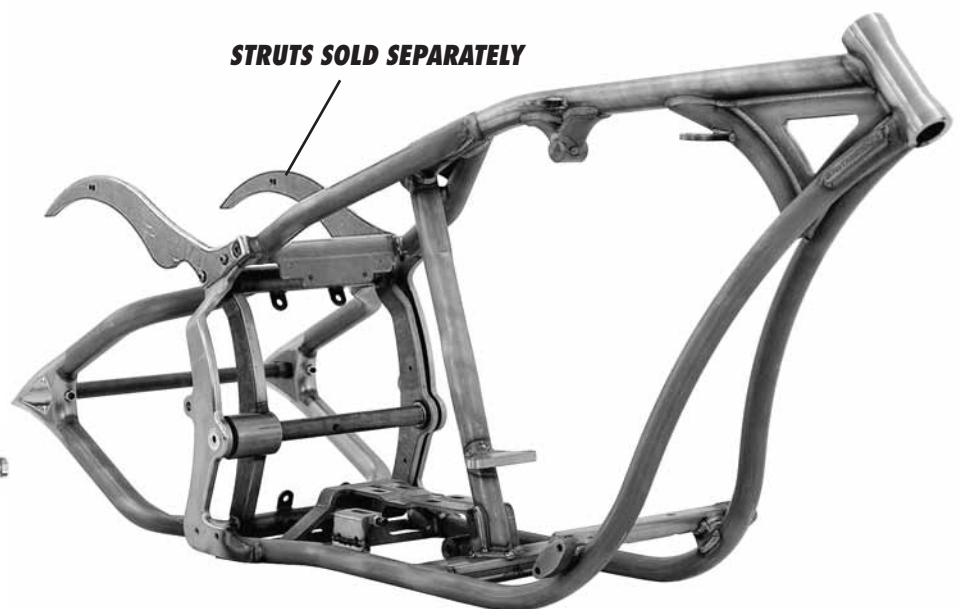
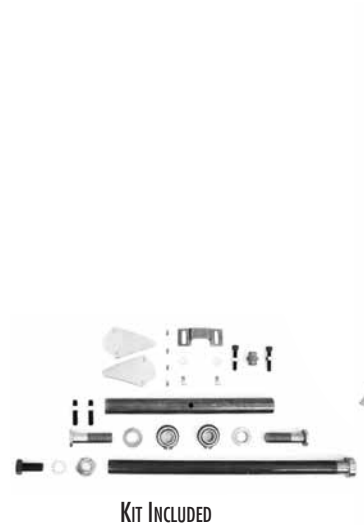

Fwd
Controls

Kickstands

Handlebars

CURVED DAGGER

PART #	STYLE	TIRE WIDTH	TUBING	RAKE	UP STRETCH	BACK BONE STR.	BACK BONE
K16129	Softail	300-330	1-1/4"	38°	0"	5"	1-1/2"
K16130	Softail	300-330	1-1/4"	40°	0"	5"	1-1/2"
K16131	Softail	300-330	1-1/4"	38°	-2"	5"	1-1/2"
K16132	Softail	300-330	1-1/4"	40°	-2"	5"	1-1/2"

Exhaust

Misc.



SOFTAIL-STYLE FRAMES / 1-1/8" TUBING / STOCK WIDTH

- * Frames are designed for removable transmission plate
- * Engineered for use with 1987-1999 rear section assemblies (Rear section not included) see page 78
- * Come equipped with stock coil & oil tank mounts, and accept Softtail style flatside gas tanks
- * Available with neck rakes of 30° / 34° / 38°

Swingarms



Fenders
Struts



SOLD SEPARATELY

Gas Tanks



Oil Tanks

<u>PART #</u>	<u>STYLE</u>	<u>TIRE WIDTH</u>	<u>TUBING</u>	<u>RAKE</u>	<u>UP STRETCH</u>
K15001	Softtail	Stock	1-1/8"	30°	0"

Fwd
Controls

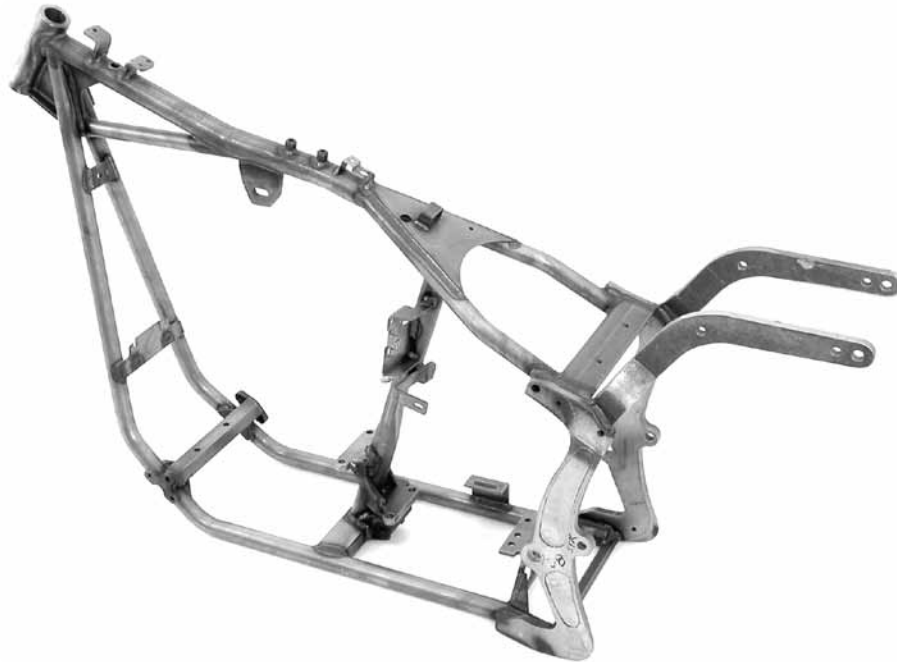

Kickstands

Handlebars



SOLD SEPARATELY

Exhaust



Misc.

<u>PART #</u>	<u>STYLE</u>	<u>TIRE WIDTH</u>	<u>TUBING</u>	<u>RAKE</u>	<u>UP STRETCH</u>
K15002	Softtail	Stock	1-1/8"	34°	2"
K15003	Softtail	Stock	1-1/8"	38°	2"

Frames



Swingarms

Fenders
Struts

Gas Tanks

Oil Tanks

AS SHOWN IN THESE PICTURES ALL STOCK COMPONENTS BOLT RIGHT ON

Fwd
Controls

Kickstands

Handlebars

Exhaust

Misc.



SOFTAIL-STYLE FRAMES / 1-1/4" TUBING / 180 TIRE WIDTH

- * Designed for 180 width tire w/1-1/2" belt or 200 width tire with chain
- * Offset built into frame / no spacing is required
- * Stock motor and transmission bolt-in...this frame uses removable trans plate
- * Component kit is included

Swingarms



Kit INCLUDED



Fenders
Struts



SOLD SEPARATELY

Gas Tanks



SOLD SEPARATELY

Oil Tanks

<u>PART #</u>	<u>STYLE</u>	<u>TIRE WIDTH</u>	<u>TUBING</u>	<u>RAKE</u>	<u>UP STRETCH</u>	<u>INCLUDES</u>
K15010	Softail	180	1-1/4"	30°	0"	Rear Section
K15011	Softail	180	1-1/4"	34°	2"	Rear Section
K15012	Softail	180	1-1/4"	38°	2"	Rear Section

Fwd
Controls

Kickstands



Kit INCLUDED



Handlebars



SOLD SEPARATELY

Exhaust



SOLD SEPARATELY

Misc.

<u>PART #</u>	<u>STYLE</u>	<u>TIRE WIDTH</u>	<u>TUBING</u>	<u>RAKE</u>	<u>UP STRETCH</u>	<u>BACK BONE STR.</u>	<u>INCLUDES</u>
K15017	Softail	180	1-1/4"	34°	4"	1-1/2"	Rear Section Assembly Kit
K15018	Softail	180	1-1/4"	38°	4"	1-1/2"	Rear Section Assembly Kit



Frames



Swingarms

Fenders
Struts

Gas Tanks

Oil Tanks

Fwd
Controls

Kickstands

Handlebars

Exhaust

Misc.



SOFTTAIL-STYLE FRAMES FOR TWIN CAM B-MOTOR

- * Replacement style frames designed for stock components
- * Frames use 2000-up Twin Cam B-Motor and transmission
- * Manufactured from 1-1/4" diameter DOM steel
- * Available with 30° and 35° neck rake angles
- * These frames are sold without rear sections, use your stock rear section assembly

1-1/4" TUBING / STOCK WIDTH



ALL FRAMES COME COMPLETE WITH A MANUFACTURER'S STATEMENT OF ORIGIN

PART #	STYLE	TIRE WIDTH	TUBING	RAKE	UP STRETCH
K10065	Softtail	Stock	1-1/4"	30°	0"
K10068	Softtail	Stock	1-1/4"	35°	0"

1-1/4" TUBING / 180-200 TIRE WIDTH

- * Enhance the overall performance and looks of your Twin Cam B-Motor project by using these KRAFT/TECH frames and rear section assemblies
- * These frames accept 2000-up Softtail Twin Cam B-motors and transmissions
- * Available with a neck rake angle of 30° or 35°
- * Frames accept most other stock components

STRUTS SOLD SEPARATELY

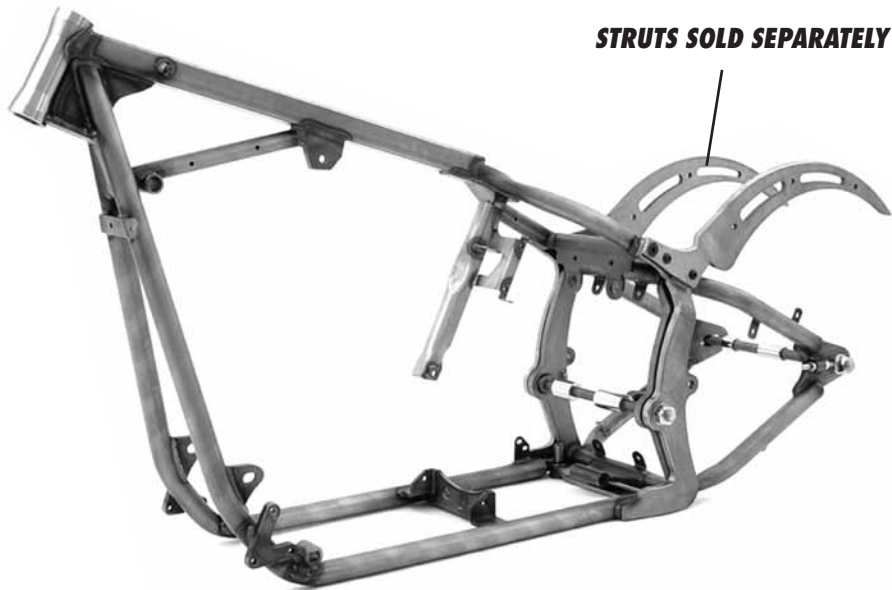

KIT INCLUDED

Misc.	PART #	STYLE	TIRE WIDTH	TUBING	RAKE	UP STRETCH
	K10066	Softtail	180-200	1-1/4"	30°	0"
	K10069	Softtail	180-200	1-1/4"	35°	0"



SOFTAIL-STYLE FRAMES FOR TWIN CAM B-MOTORS

- * Large 1-3/8" diameter DOM steel tubing, mandrel bent
- * Frames are TIG-MIG welded
- * These beauties come complete with rear sections assembly
- * These frames accept 2000-up Softail Twin Cam B-motors and transmissions
- * Frames also accept most other stock components
- * Available with neck rake angles of 30°, 35° and 38° with front leg stretches of 0" and 2"
- * Component kit is included

ALL FRAMES COME COMPLETE WITH A MANUFACTURER'S STATEMENT OF ORIGIN



1-3/8" MEGA-TUBE / STOCK WIDTH



Kit Included



optional standard

Add the letter "H" after the part # for a hidden axle rear section

PART #	STYLE	TIRE WIDTH	TUBING	RAKE	UP STRETCH	INCLUDES
K10070	Softail	Stock	1-3/8"	30°	0"	Rear Section Assembly
K10071	Softail	Stock	1-3/8"	35°	0"	Rear Section Assembly
K10072	Softail	Stock	1-3/8"	35°	2"	Rear Section Assembly
K10073	Softail	Stock	1-3/8"	38°	2"	Rear Section Assembly

Frames

Swingarms

Fenders
Struts

Gas Tanks

Oil Tanks

Fwd
Controls

Kickstands

Handlebars

Exhaust

Misc.

