



Frames

Swingarms

Fenders
Struts

Gas Tanks

Oil Tanks



RIGIDS

Fwd
Controls

Kickstands

Handlebars

Exhaust

Misc.



RIGID FRAMES / 1-1/4" TUBING

- * All DOM steel tubing, mandrel bent * TIG-MIG welded
- * Frames will accept Evolution motors (except Twin Cam), Shovelhead & Panhead engines with clearance for cylinders up to .200" taller than stock Evolution
- * Run a 5 or 6-speed Softail-type transmission in these frames

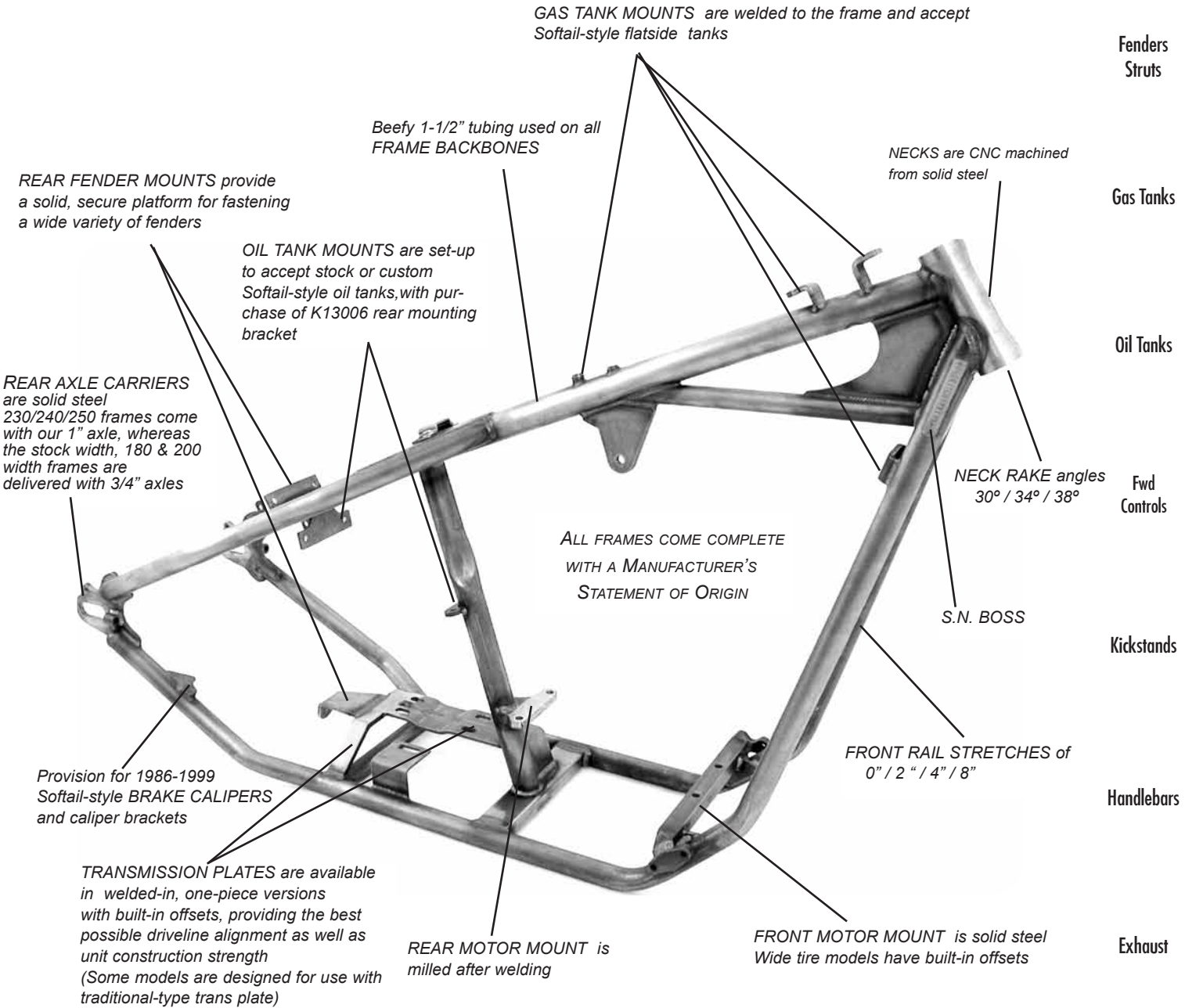

Frame shown is 4" stretch model

Swingarms

Fenders
Struts

Gas Tanks

Oil Tanks

Fwd
Controls

Kickstands

Handlebars

Exhaust

Misc.



RIGID FRAMES / 1-1/4" TUBING / STOCK WIDTH

- * Frames use stock width disc brake wheel, 1986-1999 Softail-style brakes, axles and spacers
- * Run a 1-1/2" belt (or chain) * Frame is made with an integral 1-piece transmission mount for Softail-style 5-speeds
- * Component kits are included, where indicated

Swingarms

Fenders
Struts

Gas Tanks



Oil Tanks



Fwd
Controls

PART #	STYLE	TIRE WIDTH	TUBING	RAKE	UP STRETCH
K16051	Rigid	Stock	1-1/4"	30°	0"
K16052	Rigid	Stock	1-1/4"	34°	2"

Kickstands

Handlebars



INCLUDED

Exhaust



Misc.

PART #	STYLE	TIRE WIDTH	TUBING	RAKE	UP STRETCH	BACK BONE STR.
K16054	Rigid	Stock	1-1/4"	34°	4"	1-1/2"
K16055	Rigid	Stock	1-1/4"	38°	4"	1-1/2"

RIGID FRAMES / 1-1/4" TUBING / 180 TIRE WIDTH

- * Designed for 180 width tire w/1-1/2" belt or 200 width tire with a chain
- * Offset built into frame...no spacing required * Stock motor and transmission bolt right in without modification
- * Trans mount built into frame, providing additional strength & accurate driveline alignment
- * Component kit is included

Frames



KIT INCLUDED



SOLD SEPARATELY

Swingarms

Fenders
Struts

Gas Tanks

Oil Tanks

<u>PART #</u>	<u>STYLE</u>	<u>TIRE WIDTH</u>	<u>TUBING</u>	<u>RAKE</u>	<u>UP STRETCH</u>	<u>INCLUDES</u>
K16056	Rigid	180	1-1/4"	30°	0"	Axle Kit
K16057	Rigid	180	1-1/4"	34°	2"	Axle Kit
K16058	Rigid	180	1-1/4"	38°	2"	Axle Kit

Fwd
Controls



KIT INCLUDED



SOLD SEPARATELY

Kickstands

Handlebars

Exhaust

<u>PART #</u>	<u>STYLE</u>	<u>TIRE WIDTH</u>	<u>TUBING</u>	<u>RAKE</u>	<u>UP STRETCH</u>	<u>BACK BONE STR.</u>	<u>INCLUDES</u>
K16060	Rigid	180	1-1/4"	34°	4"	1-1/2"	Axle Kit
K16061	Rigid	180	1-1/4"	38°	4"	1-1/2"	Axle Kit

Misc.

RIGID FRAMES / 1-1/4" TUBING / 200 TIRE WIDTH

- * Designed for 200 width tire w/1-1/2" belt or chain
- * Offset is built into the frame...use 1/2" spacer between engine and inner primary cover
- use 1/2" longer spacing on engine sprocket or pulley
- * Component kit is included

Swingarms



Fenders
Struts



Kit INCLUDED

Gas Tanks

Oil Tanks



<u>PART #</u>	<u>STYLE</u>	<u>TIRE WIDTH</u>	<u>TUBING</u>	<u>RAKE</u>	<u>UP STRETCH</u>	<u>BACK BONE STR.</u>	<u>INCLUDES</u>
K16074	Rigid	200	1-1/4"	34°	4"	1-1/2"	Axle Kit

Fwd
Controls

Kickstands

Handlebars

Exhaust



Kit INCLUDED

Misc.

<u>PART #</u>	<u>STYLE</u>	<u>TIRE WIDTH</u>	<u>TUBING</u>	<u>RAKE</u>	<u>UP STRETCH</u>	<u>BACK BONE STR.</u>	<u>INCLUDES</u>
K16063	Rigid	200	1-1/4"	34°	8"	4"	Axle Kit
K16064	Rigid	200	1-1/4"	38°	8"	4"	Axle Kit



RIGID FRAMES / 1-1/4" TUBING / 230/240/250 TIRE WIDTH

- * Designed for 230/240 tires using a 1-1/2" belt (or chain), and 250 width tires using a 1-1/8" belt (or chain)
- * 1-piece transmission mount is welded to frame and provides unit construction strength & better driveline alignment
- * Offset is built into frame...use 1" spacer between engine and inner primary cover
use 1" spacer on engine sprocket or pulley
- * Component kit is included

Frames



Swingarms

Fenders
Struts

Gas Tanks

Oil Tanks

<u>PART #</u>	<u>STYLE</u>	<u>TIRE WIDTH</u>	<u>TUBING</u>	<u>RAKE</u>	<u>UP STRETCH</u>	<u>INCLUDES</u>
K16066	Rigid	230/240/250	1-1/4"	34°	2"	1" Axle Kit
K16068	Rigid	230/240/250	1-1/4"	38°	2"	1" Axle Kit

Fwd Controls

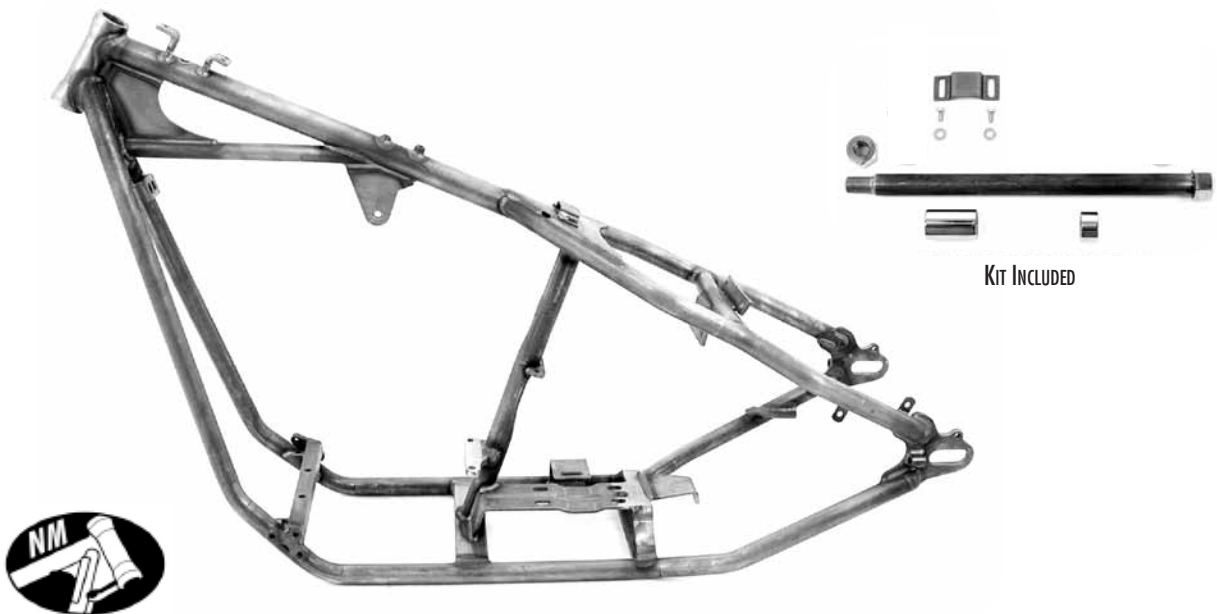

Kickstands

Handlebars

Exhaust

<u>PART #</u>	<u>STYLE</u>	<u>TIRE WIDTH</u>	<u>TUBING</u>	<u>RAKE</u>	<u>UP STRETCH</u>	<u>BACK BONE STR.</u>	<u>INCLUDES</u>
K16071	Rigid	230/240/250	1-1/4"	34°	4"	1-1/2"	Axle Kit
K16073	Rigid	230/240/250	1-1/4"	38°	4"	1-1/2"	Axle Kit

Misc.

RIGID FRAMES / 1-1/4" TUBING / STOCK WIDTH

- * Frames are designed for removable transmission plate for chain drive 4 and 5-speeds
- * Uses stock width disc brake wheel, Softtail-style brakes (pre-2000), axle & adjusters

Swingarms

Fenders
Struts

Gas Tanks

Oil Tanks

Fwd
Controls

Kickstands

Handlebars



Exhaust

<u>PART #</u>	<u>STYLE</u>	<u>TIRE WIDTH</u>	<u>TUBING</u>	<u>RAKE</u>	<u>UP STRETCH</u>
K16001	Rigid	Stock	1-1/4"	30°	0"
K16002	Rigid	Stock	1-1/4"	34°	2"

Misc.



RIGID FRAMES / 1-1/4" TUBING / 180 TIRE WIDTH

- * Frames are engineered for 180 tire w/ 1-1/2" belt or 200 tire with chain
- * Offset built into frame. .no spacing required
- * Stock motor and transmission bolt-in
- * Accepts 4 or 5-speed transmissions
- * Requires using a removable trans plate
- * Component kit is included

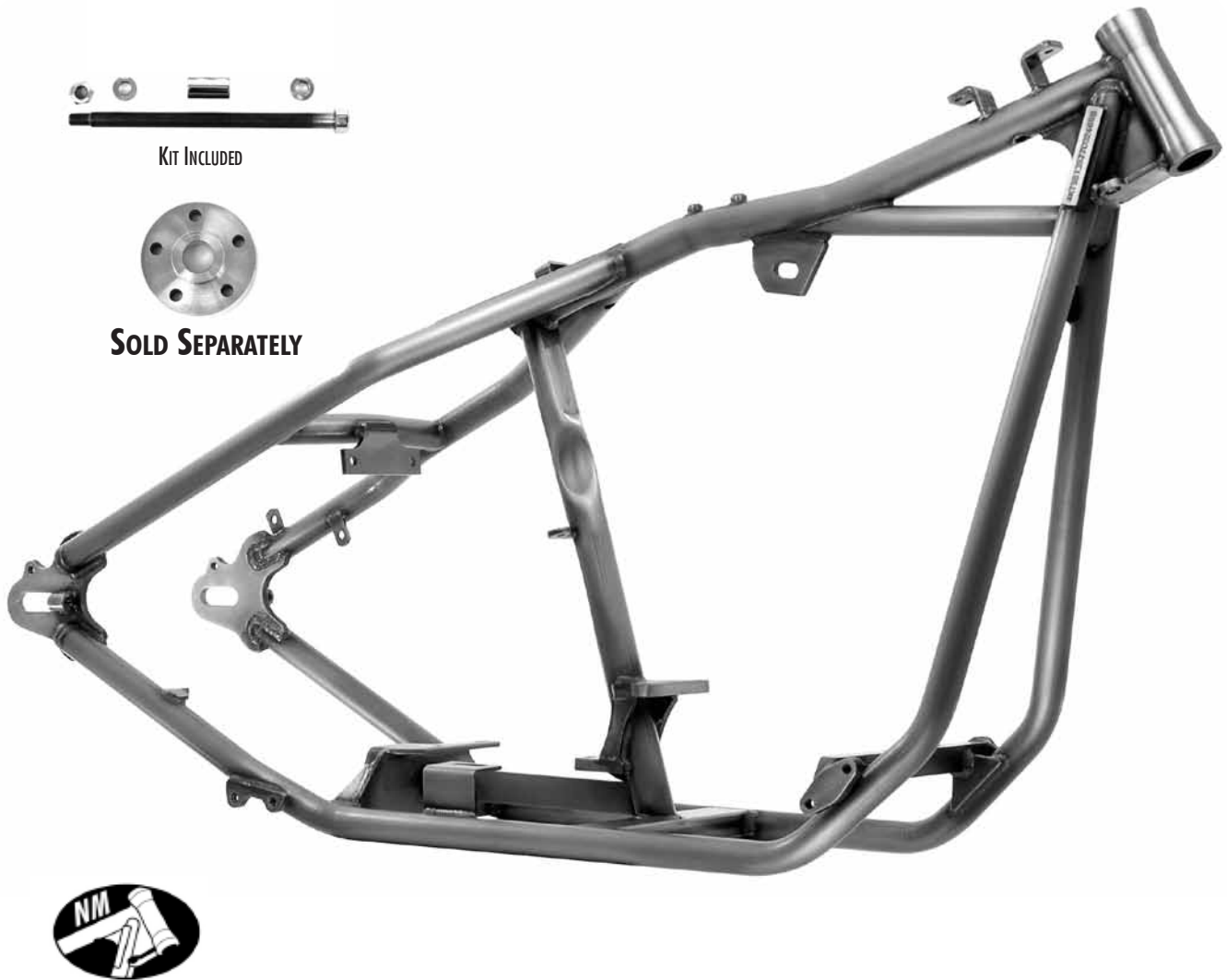

Swingarms

Fenders
Struts

Gas Tanks

Oil Tanks

Fwd
Controls

Kickstands

Handlebars

Exhaust

Misc.

<u>PART #</u>	<u>STYLE</u>	<u>TIRE WIDTH</u>	<u>TUBING</u>	<u>RAKE</u>	<u>UP STRETCH</u>	<u>INCLUDES</u>
K16006	Rigid	180	1-1/4"	30°	0"	Axle Kit
K16007	Rigid	180	1-1/4"	34°	2"	Axle Kit
K16008	Rigid	180	1-1/4"	38°	2"	Axle Kit

RIGID FRAMES / 1-1/4" TUBING / 180 TIRE WIDTH

- * Frames are engineered for 180 tire w/ 1-1/2" belt or 200 tire with chain
- * Offset built into frame. .no spacing required
- * Stock motor and transmission bolt-in
- * Accepts 4 or 5-speed transmissions
- * Requires using a removable trans plate
- * Component kit is included

Swingarms

Fenders
Struts

Gas Tanks

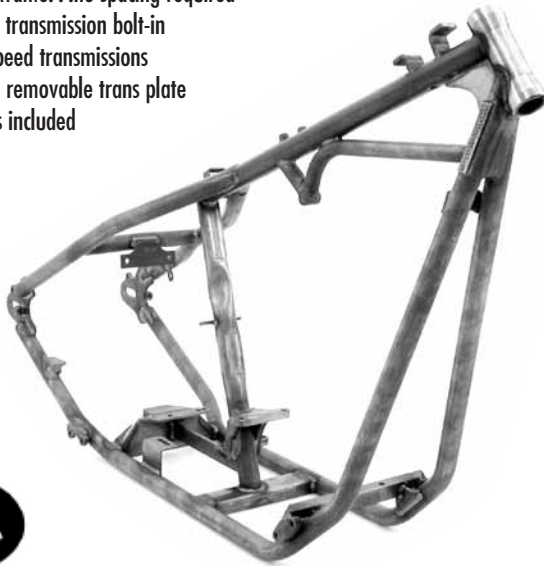

Kit Included



SOLD SEPARATELY

Oil Tanks

PART #	STYLE	TIRE WIDTH	TUBING	RAKE	UP STRETCH	BACK BONE STR.	INCLUDES
K16010	Rigid	180	1-1/4"	34°	4"	1-1/2"	Axle Kit
K16011	Rigid	180	1-1/4"	38°	4"	1-1/2"	Axle Kit

Fwd
Controls

RIGID FRAMES / 1-1/4" TUBING / 230/240/250 TIRE WIDTH

- * Run a 230/240 tire with a 1-1/2" belt or chain, 250 tire with 1-1/8" belt or chain
- * Offset built into frame. .requires 1" spacing between engine & inner primary cover and 1" spacer on engine sprocket or pulley
- * Accepts 5-speed transmissions
- * Requires using a removable transmission plate
- * Component kit is included

Kickstands

Handlebars

Exhaust



Kit Included



Misc.

PART #	STYLE	TIRE WIDTH	TUBING	RAKE	UP STRETCH	INCLUDES
K16016	Rigid	230/240/250	1-1/4"	38°	2"	Axle Kit



RIGID SPORTSTER FRAMES / 1-1/4" TUBING

- * Feature 1-1/4" thick wall, DOM steel tubing with 1-1/2" backbones
- * All frames are TIG-MIG welded & will accept Sportster Engines(1986-2003)
- * Component Kits are included with purchase of frame... These kits are not sold separately
- * Standard frames accept a 130 tire with a conventional 1-1/8" belt drive assembly or chain, and 180 width frames can take a stock belt, or a 200-series tire when using a chain.
- * Frame is designed to use a 1/2" transmission off-set sprocket for proper balance.
- * Available with neck rakes of 30° and 34° and up-stretches of 0"/ 2"/ 3"/ and 4".

Swingarms

Fenders
Struts

ALL FRAMES COME COMPLETE WITH A MANUFACTURER'S STATEMENT OF ORIGIN

Gas Tanks

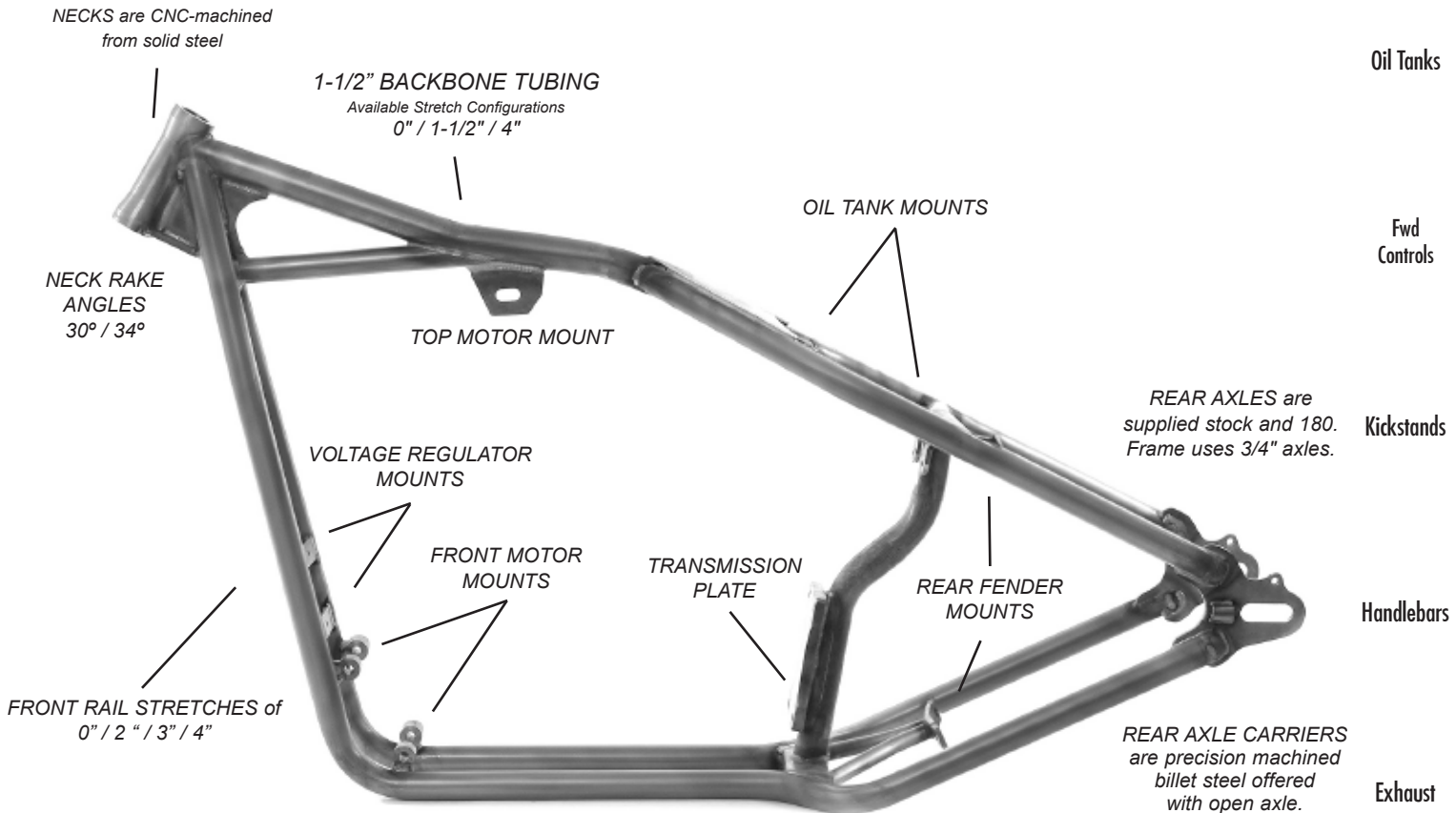

Oil Tanks

Fwd
Controls

Kickstands

Handlebars

Exhaust

Misc.

